

Write your name here

Surname	Other names
---------	-------------

**Pearson Edexcel
International GCSE**

Centre Number	Candidate Number
<input style="width: 20px; height: 20px; border: 1px solid black;" type="text"/> <input style="width: 20px; height: 20px; border: 1px solid black;" type="text"/> <input style="width: 20px; height: 20px; border: 1px solid black;" type="text"/> <input style="width: 20px; height: 20px; border: 1px solid black;" type="text"/> <input style="width: 20px; height: 20px; border: 1px solid black;" type="text"/>	<input style="width: 20px; height: 20px; border: 1px solid black;" type="text"/> <input style="width: 20px; height: 20px; border: 1px solid black;" type="text"/> <input style="width: 20px; height: 20px; border: 1px solid black;" type="text"/> <input style="width: 20px; height: 20px; border: 1px solid black;" type="text"/>

Physics

Unit: 4PH0

Paper: 2P

Thursday 18 January 2018 – Afternoon Time: 1 hour	Paper Reference 4PH0/2P
---	-----------------------------------

You must have: Ruler, calculator	Total Marks <input style="width: 80%; height: 30px; border: 1px solid black;" type="text"/>
--	--

Instructions

- Use **black** ink or ball-point pen.
- **Fill in the boxes** at the top of this page with your name, centre number and candidate number.
- Answer **all** questions.
- Answer the questions in the spaces provided
– *there may be more space than you need.*
- Show all the steps in any calculations and state the units.

Information

- The total mark for this paper is 60.
- The marks for **each** question are shown in brackets
– *use this as a guide as to how much time to spend on each question.*

Advice

- Read each question carefully before you start to answer it.
- Write your answers neatly and in good English.
- Try to answer every question.
- Check your answers if you have time at the end.

Turn over ►

P53282A

©2018 Pearson Education Ltd.

1/1/1/1/1/



Pearson

EQUATIONS

You may find the following equations useful.

$$\text{energy transferred} = \text{current} \times \text{voltage} \times \text{time}$$

$$E = I \times V \times t$$

$$\text{pressure} \times \text{volume} = \text{constant}$$

$$p_1 \times V_1 = p_2 \times V_2$$

$$\text{frequency} = \frac{1}{\text{time period}}$$

$$f = \frac{1}{T}$$

$$\text{power} = \frac{\text{work done}}{\text{time taken}}$$

$$P = \frac{W}{t}$$

$$\text{power} = \frac{\text{energy transferred}}{\text{time taken}}$$

$$P = \frac{W}{t}$$

$$\text{orbital speed} = \frac{2\pi \times \text{orbital radius}}{\text{time period}}$$

$$v = \frac{2 \times \pi \times r}{T}$$

$$\frac{\text{pressure}}{\text{temperature}} = \text{constant}$$

$$\frac{p_1}{T_1} = \frac{p_2}{T_2}$$

$$\text{force} = \frac{\text{change in momentum}}{\text{time taken}}$$

Where necessary, assume the acceleration of free fall, $g = 10 \text{ m/s}^2$.

DO NOT WRITE IN THIS AREA

DO NOT WRITE IN THIS AREA

DO NOT WRITE IN THIS AREA

DO NOT WRITE IN THIS AREA

DO NOT WRITE IN THIS AREA

DO NOT WRITE IN THIS AREA



Answer ALL questions.

1 (a) The table lists some energy sources.

Put ticks in boxes to show which energy sources are non-renewable.

(3)

Energy source	Tick
wind	
oil	
coal	
geothermal	
bio-gas	
nuclear	

(b) Give an advantage and a disadvantage of using fossil fuels to generate electricity.

(2)

advantage

.....

disadvantage

.....

(Total for Question 1 = 5 marks)



DO NOT WRITE IN THIS AREA

DO NOT WRITE IN THIS AREA

DO NOT WRITE IN THIS AREA

DO NOT WRITE IN THIS AREA

DO NOT WRITE IN THIS AREA

DO NOT WRITE IN THIS AREA

2 (a) (i) State the relationship between power, current and voltage.

(1)

(ii) A lamp with a power of 6.5 W is connected to a 230 V supply.

Calculate the current in the lamp.

(3)

current = A

DO NOT WRITE IN THIS AREA

DO NOT WRITE IN THIS AREA

DO NOT WRITE IN THIS AREA

DO NOT WRITE IN THIS AREA

DO NOT WRITE IN THIS AREA

DO NOT WRITE IN THIS AREA



(b) Three switches, S1, S2 and S3, are used to control a lamp in a large room.

Each switch can be up or down, and each switch can turn the lamp on or off.

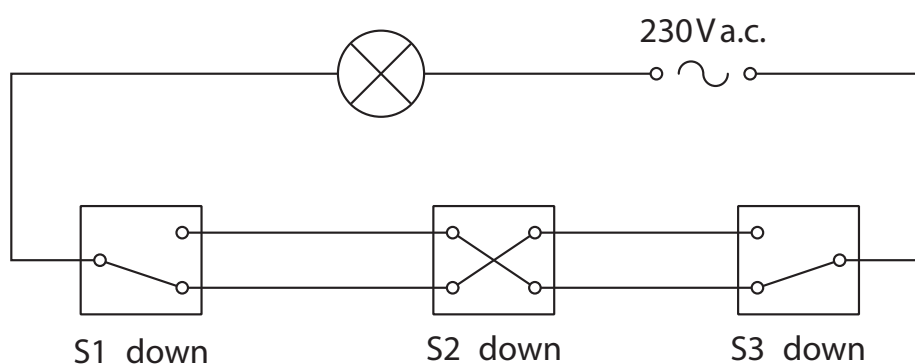
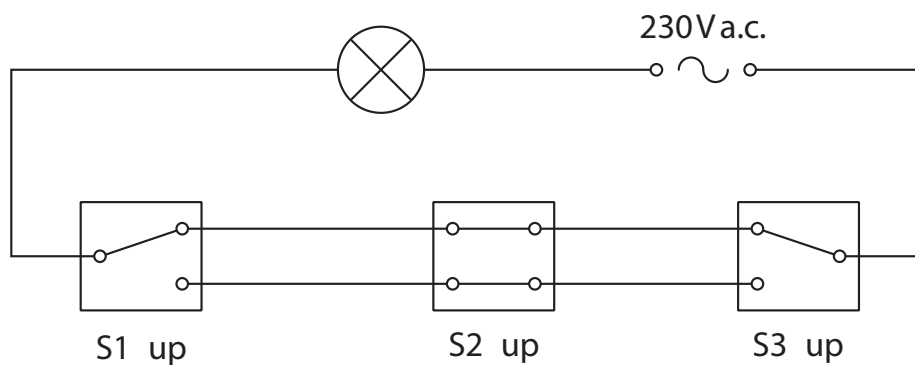

When all three switches are up, the lamp is on.

When all three switches are down, the lamp is off.

Complete the table by giving the missing information.

(3)

S1	S2	S3	Lamp
up	up	up	on
down	down	down	off
up	up	down	
down	up		off
up		down	on

(Total for Question 2 = 7 marks)



3 A student investigates different properties of waves.

(a) He uses this ripple tank to investigate diffraction.

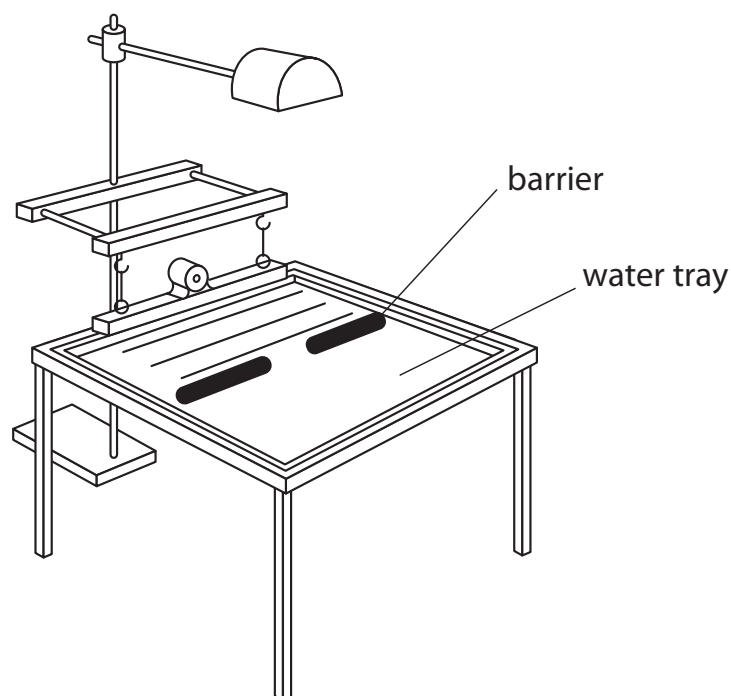

The ripple tank produces plane waves.

These waves hit a barrier with a gap in it.

The student keeps the wavelength constant but varies the size of the gap in the barrier.

Complete the diagrams to show what happens to the plane waves as they go through the different sized gaps in the barrier.

(3)

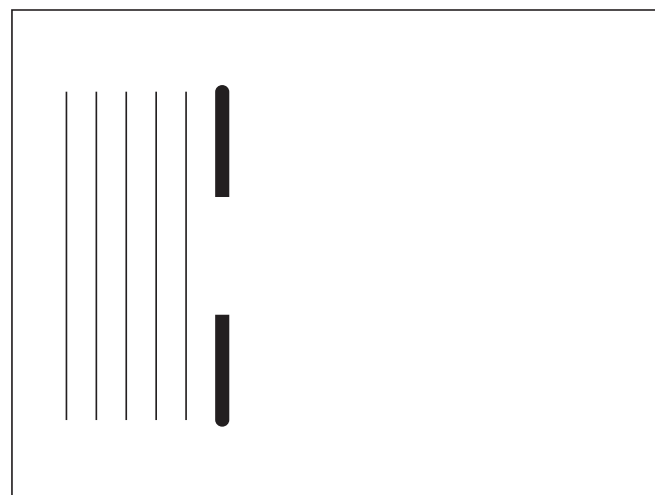
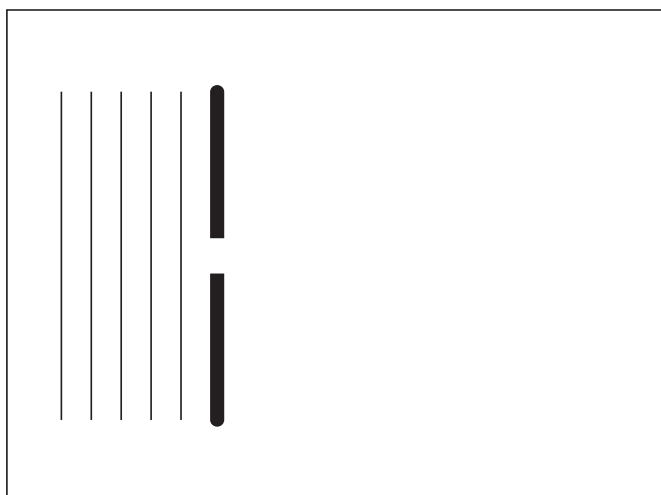

DO NOT WRITE IN THIS AREA

DO NOT WRITE IN THIS AREA

DO NOT WRITE IN THIS AREA

DO NOT WRITE IN THIS AREA

DO NOT WRITE IN THIS AREA

DO NOT WRITE IN THIS AREA



(b) The student removes the barrier and investigates what happens when the plane wave travels into a shallow part of the ripple tank.

(i) State the relationship between the speed, frequency and wavelength of a wave. (1)

(ii) Waves in the deep part of the ripple tank have a speed of 6.0 cm/s and a wavelength of 4.0 cm.

Waves in the shallow part of the ripple tank have a speed of 4.0 cm/s.

The frequency of the waves stays the same.

Show that the wavelength in the shallow part of the ripple tank is approximately 3 cm. (3)

(Total for Question 3 = 7 marks)



4 This question is about collisions.

The diagram shows ball A moving in the direction shown by the arrow.

Ball A collides with ball B, a stationary ball of the same mass and size as ball A.

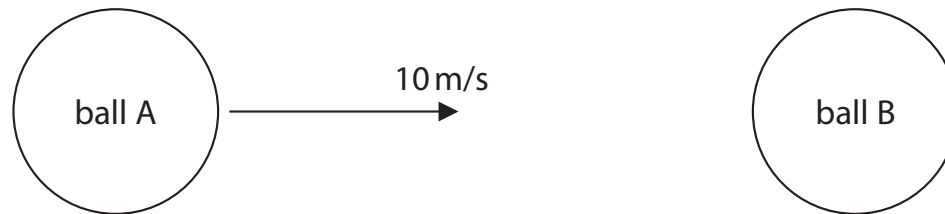

(a) State the principle of conservation of momentum.

(1)

(b) Ball A collides with ball B.

- before the collision, ball A moves with a velocity of 10 m/s
- after the collision, ball B moves in the same direction as ball A with a velocity of 8 m/s
- ball A continues to move in the same direction, but at a lower velocity

Calculate the velocity of ball A after the collision.

[mass of each ball = 0.16 kg]

(3)

velocity of ball A = m/s

DO NOT WRITE IN THIS AREA

DO NOT WRITE IN THIS AREA

DO NOT WRITE IN THIS AREA

DO NOT WRITE IN THIS AREA

DO NOT WRITE IN THIS AREA

DO NOT WRITE IN THIS AREA



(c) During the collision some kinetic energy is lost.

Calculate the kinetic energy lost in the collision.

$$[\text{kinetic energy} = \frac{1}{2} \times \text{mass} \times \text{velocity}^2]$$

(3)

kinetic energy lost = J

(Total for Question 4 = 7 marks)

DO NOT WRITE IN THIS AREA

DO NOT WRITE IN THIS AREA

DO NOT WRITE IN THIS AREA

DO NOT WRITE IN THIS AREA

DO NOT WRITE IN THIS AREA

DO NOT WRITE IN THIS AREA



P 5 3 2 8 2 A 0 9 2 0



BLANK PAGE

DO NOT WRITE IN THIS AREA

DO NOT WRITE IN THIS AREA

DO NOT WRITE IN THIS AREA

DO NOT WRITE IN THIS AREA

DO NOT WRITE IN THIS AREA

DO NOT WRITE IN THIS AREA



5 A teacher demonstrates the effect of air pressure.

(a) The teacher inflates a balloon and places it inside a bell jar.

He fixes the bell jar firmly to a bench.

He then uses a pump to remove some of the air from the bell jar.

The balloon increases in size.

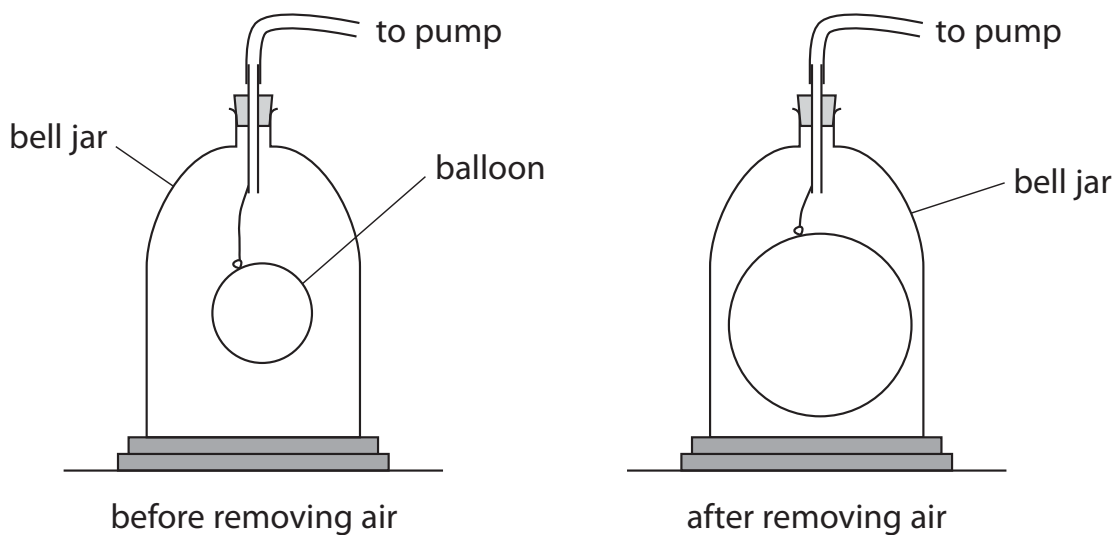

Explain, in terms of kinetic theory of particles, why the balloon increases in size.

(4)

.....

.....

.....

.....

.....

.....

.....

.....

.....

.....



DO NOT WRITE IN THIS AREA

DO NOT WRITE IN THIS AREA

DO NOT WRITE IN THIS AREA

DO NOT WRITE IN THIS AREA

DO NOT WRITE IN THIS AREA

DO NOT WRITE IN THIS AREA

(b) The teacher then sets up this apparatus.

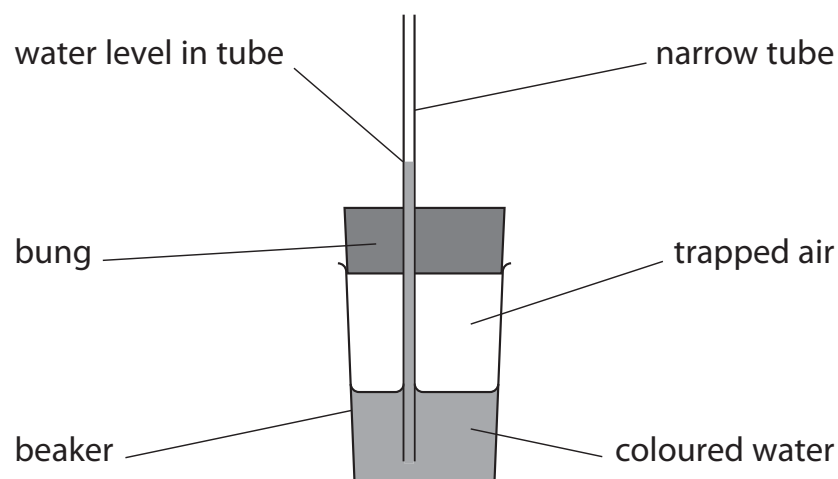

He uses a bung fitted with a narrow tube, and a beaker containing some coloured water.

He pushes the bung into the beaker trapping some air. Water rises up the narrow tube.

(i) Explain what would happen to the pressure of the trapped air if the bung is pushed further into the beaker.

(2)

.....

.....

.....

.....

(ii) Explain what would happen to the water level in the narrow tube if the bung is pushed further into the beaker.

(2)

.....

.....

.....

.....

DO NOT WRITE IN THIS AREA

DO NOT WRITE IN THIS AREA

DO NOT WRITE IN THIS AREA

DO NOT WRITE IN THIS AREA

DO NOT WRITE IN THIS AREA

DO NOT WRITE IN THIS AREA



(iii) Explain what would happen to the water level in the narrow tube if the pressure of the air outside the beaker increases.

(2)

.....

.....

.....

.....

(Total for Question 5 = 10 marks)

DO NOT WRITE IN THIS AREA

DO NOT WRITE IN THIS AREA

DO NOT WRITE IN THIS AREA

DO NOT WRITE IN THIS AREA

DO NOT WRITE IN THIS AREA

DO NOT WRITE IN THIS AREA



P 5 3 2 8 2 A 0 1 3 2 0

- 6 A student uses this apparatus to investigate how the strength of the magnetic field in a current-carrying coil varies as the current changes.

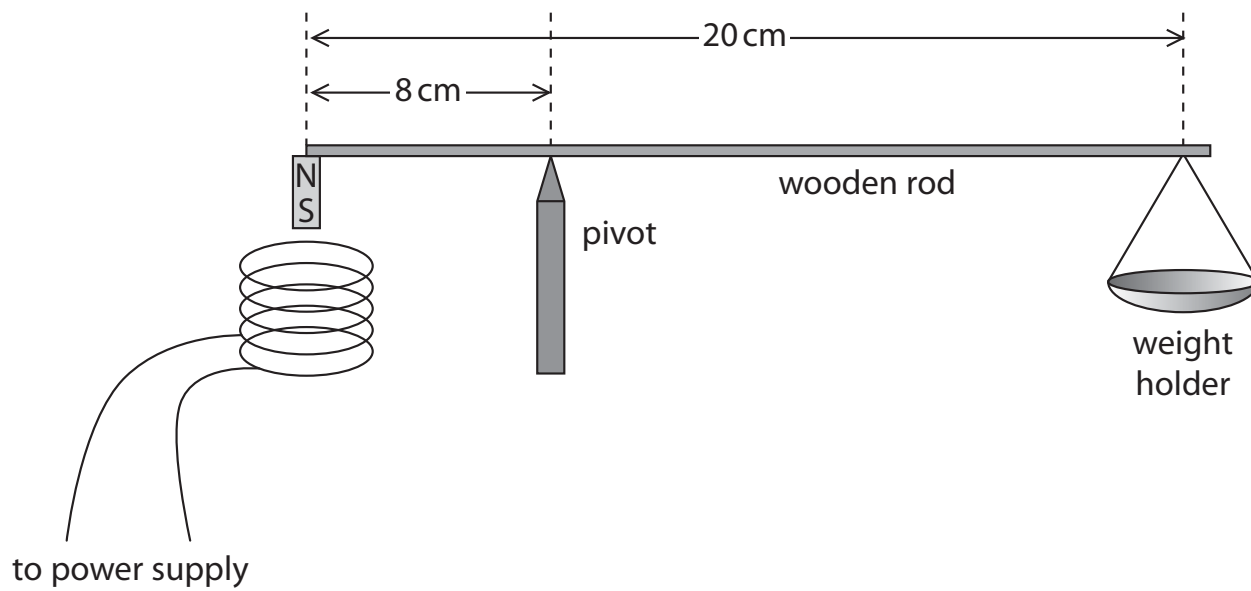

This is the student's method.

- attach a small magnet to one end of a wooden rod
 - place the rod on a pivot that is 8 cm from the magnet
 - attach a weight holder to the other end of the rod
 - place a current-carrying coil underneath the magnet
- (a) A weight of 0.1 N is needed to balance the rod when the current in the coil is zero.

Calculate the weight of the magnet.
[ignore weight of rod and weight holder]

(3)

weight of magnet = N

DO NOT WRITE IN THIS AREA

DO NOT WRITE IN THIS AREA

DO NOT WRITE IN THIS AREA

DO NOT WRITE IN THIS AREA

DO NOT WRITE IN THIS AREA

DO NOT WRITE IN THIS AREA



(b) The student increases the current and observes that the rod rotates anticlockwise and the magnet moves towards the coil.

Explain this observation.

(3)

.....

.....

.....

.....

.....

.....

DO NOT WRITE IN THIS AREA

DO NOT WRITE IN THIS AREA

DO NOT WRITE IN THIS AREA

DO NOT WRITE IN THIS AREA

DO NOT WRITE IN THIS AREA

DO NOT WRITE IN THIS AREA



P 5 3 2 8 2 A 0 1 5 2 0

(c) The student adds weights to balance the rod for different currents.

The table shows her results.

Current in A	Total weight added in N
0.0	0.1
0.1	0.5
0.5	2.1
0.7	2.5
0.9	3.7
1.1	4.5

- (i) Plot a graph of the student's results, with the independent variable on the x-axis. (4)
- (ii) Draw a straight line of best fit. (1)

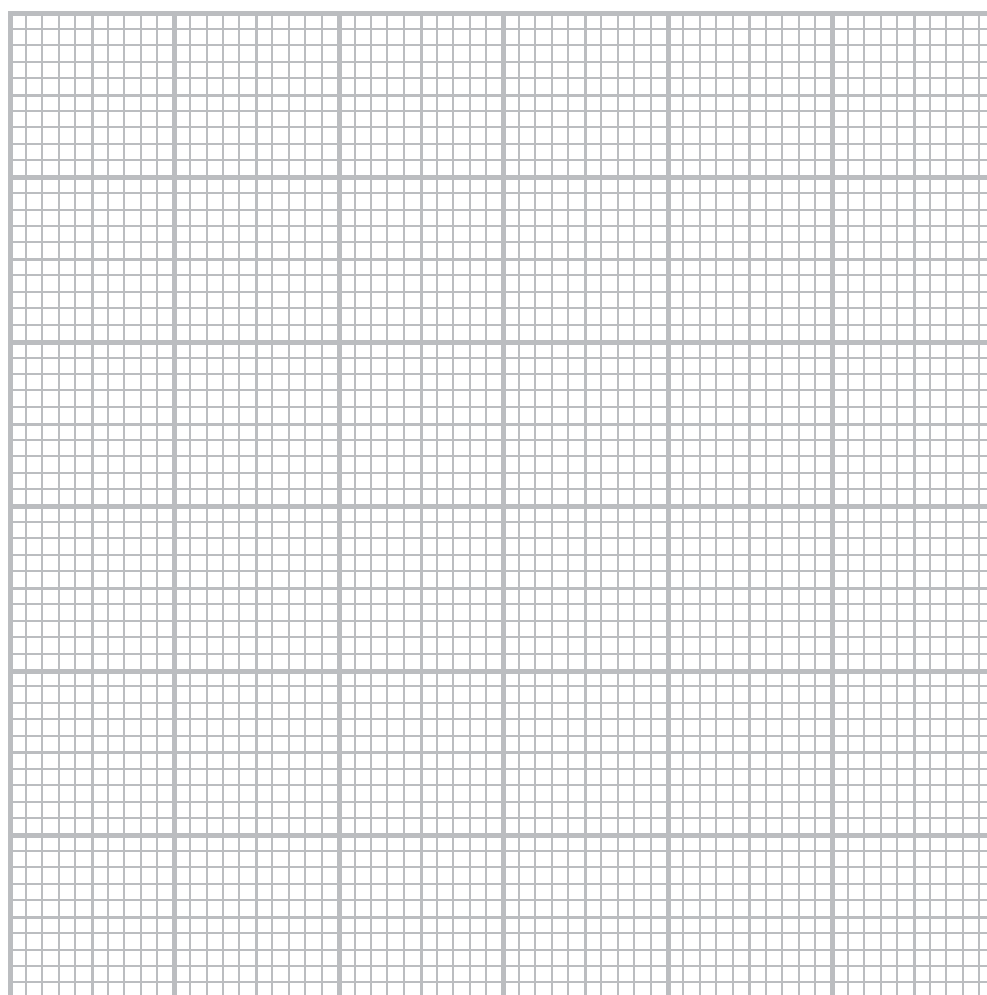

DO NOT WRITE IN THIS AREA

DO NOT WRITE IN THIS AREA

DO NOT WRITE IN THIS AREA

DO NOT WRITE IN THIS AREA

DO NOT WRITE IN THIS AREA

DO NOT WRITE IN THIS AREA



(iii) Suggest why the student should repeat the reading for a current of 0.7 A.

(2)

.....

.....

.....

.....

(iv) Describe the relationship between the current and the force produced by the magnetic field.

(2)

.....

.....

.....

.....

(v) Estimate the weight needed to balance the rod when the current is 2 A.

(2)

weight needed = N

(Total for Question 6 = 17 marks)



7 A student uses a solution of solvent and oil to estimate the length of an oil molecule.

(a) (i) Name an instrument that the student could use to accurately measure 10 cm^3 of the solution.

(1)

(ii) The student uses a dropper to produce drops of the solution.

There are 2000 drops in 10 cm^3 of the solution.

Calculate the volume of 1 drop.

(1)

volume of 1 drop = cm^3

(b) The student adds a drop of the solution to a tray of water.

She measures the diameter of the oil film that forms.

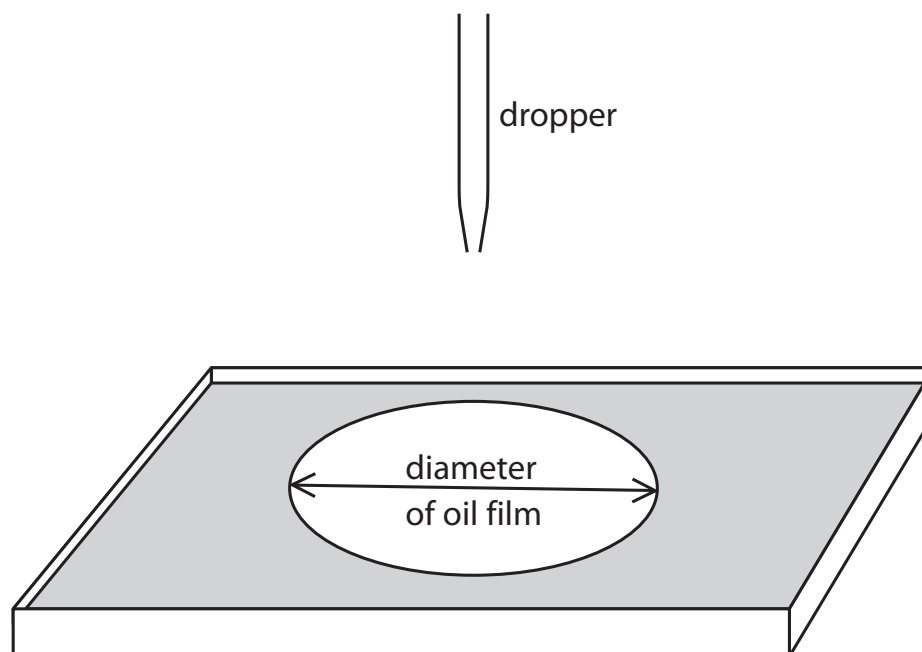

The student measures the diameter of the oil film several times.

The table shows her results.

Diameter in mm	305	301	297	298	303
-----------------------	-----	-----	-----	-----	-----

DO NOT WRITE IN THIS AREA

DO NOT WRITE IN THIS AREA

DO NOT WRITE IN THIS AREA

DO NOT WRITE IN THIS AREA

DO NOT WRITE IN THIS AREA

DO NOT WRITE IN THIS AREA



- (i) Calculate the average (mean) diameter of the oil film.

Give your answer to three significant figures.

(2)

average diameter = mm

- (ii) When the drop touches the water, the solvent evaporates and an oil film forms with thickness equal to the length of one oil molecule.

The volume of the oil film is 1.0 mm^3 .

The thickness of the oil film can be found using the formula

$$\text{volume} = \pi r^2 t$$

[r = radius of film, t = thickness of film]

Calculate the length of one oil molecule.

(3)

length = mm

(Total for Question 7 = 7 marks)

TOTAL FOR PAPER = 60 MARKS



DO NOT WRITE IN THIS AREA

DO NOT WRITE IN THIS AREA

DO NOT WRITE IN THIS AREA

DO NOT WRITE IN THIS AREA

DO NOT WRITE IN THIS AREA

DO NOT WRITE IN THIS AREA

DO NOT WRITE IN THIS AREA

DO NOT WRITE IN THIS AREA

DO NOT WRITE IN THIS AREA

BLANK PAGE

Every effort has been made to contact copyright holders to obtain their permission for the use of copyright material. Pearson Education Ltd. will, if notified, be happy to rectify any errors or omissions and include any such rectifications in future editions.

