

Write your name here

Surname

Other names

Pearson Edexcel Certificate
Pearson Edexcel
International GCSE

Centre Number

--	--	--	--	--

Candidate Number

--	--	--	--

Physics

Unit: KPH0/4PH0**Paper: 2P**

Friday 12 June 2015 – Afternoon

Time: 1 hour

Paper Reference

KPH0/2P
4PH0/2P**You must have:**

Ruler, calculator

Total Marks

Instructions

- Use **black** ink or ball-point pen.
- **Fill in the boxes** at the top of this page with your name, centre number and candidate number.
- Answer **all** questions.
- Answer the questions in the spaces provided
– *there may be more space than you need.*
- Show all the steps in any calculations and state the units.
- Some questions must be answered with a cross in a box . If you change your mind about an answer, put a line through the box and then mark your new answer with a cross .

Information

- The total mark for this paper is 60.
- The marks for **each** question are shown in brackets
– *use this as a guide as to how much time to spend on each question.*

Advice

- Read each question carefully before you start to answer it.
- Keep an eye on the time.
- Write your answers neatly and in good English.
- Try to answer every question.
- Check your answers if you have time at the end.

Turn over ►

P44231A

©2015 Pearson Education Ltd.

1/1/1

**PEARSON**

EQUATIONS

You may find the following equations useful.

$$\text{energy transferred} = \text{current} \times \text{voltage} \times \text{time}$$

$$E = I \times V \times t$$

$$\text{pressure} \times \text{volume} = \text{constant}$$

$$p_1 \times V_1 = p_2 \times V_2$$

$$\text{frequency} = \frac{1}{\text{time period}}$$

$$f = \frac{1}{T}$$

$$\text{power} = \frac{\text{work done}}{\text{time taken}}$$

$$P = \frac{W}{t}$$

$$\text{power} = \frac{\text{energy transferred}}{\text{time taken}}$$

$$P = \frac{W}{t}$$

$$\text{orbital speed} = \frac{2\pi \times \text{orbital radius}}{\text{time period}}$$

$$v = \frac{2 \times \pi \times r}{T}$$

$$\frac{\text{pressure}}{\text{temperature}} = \text{constant}$$

$$\frac{p_1}{T_1} = \frac{p_2}{T_2}$$

$$\text{force} = \frac{\text{change in momentum}}{\text{time taken}}$$

Where necessary, assume the acceleration of free fall, $g = 10 \text{ m/s}^2$.





BLANK PAGE



Answer ALL questions.

1 The chart lists some electromagnetic radiations.

radio	microwave	infrared	visible light	ultraviolet	x-ray	gamma
-------	-----------	----------	---------------	-------------	-------	-------

(a) Complete the table by giving one radiation from the chart for each use.

You may give each type of radiation once, more than once or not at all.

(3)

Use for radiation	Type of radiation
cooking	
treating cancer	
identifying broken bones	

(b) All types of electromagnetic radiation from the Sun are emitted with

(1)

- A** the same amplitude
- B** the same frequency
- C** the same speed
- D** the same wavelength



(c) William Herschel was a scientist who investigated infrared radiation.

He passed electromagnetic radiation from the Sun through a triangular glass prism.

The prism refracted different radiations by different amounts.

The paths of yellow and blue visible light rays are shown in the diagram.

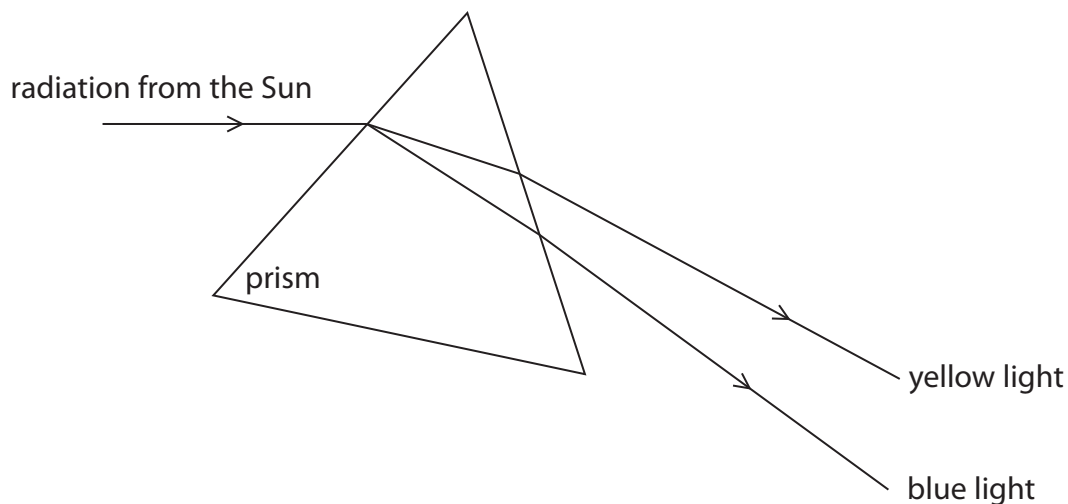

(i) Add to the diagram to show how the prism refracts an infrared ray.

(2)

(ii) William Herschel used a thermometer to detect infrared radiation.

He coloured the surface of his thermometer to make it more effective.

Which colour surface would work best?

(1)

- A black
- B red
- C silver
- D white

(Total for Question 1 = 7 marks)



2 An electric kettle is connected to the 230 V mains supply.

The power of the kettle is 960 W.



(a) (i) A power of 960 watts is the same as

(1)

- A 960 joules per coulomb
- B 960 joules per second
- C 960 newtons per metre
- D 960 newtons per second

(ii) State the equation linking power, current and voltage.

(1)

(iii) Show that the current in the kettle is about 4 A.

(2)



(b) The 960 W kettle is earthed and fitted with a fuse.

(i) Explain how this can protect the person using the kettle if there is a fault.

(3)

.....

.....

.....

.....

.....

.....

.....

.....

.....

.....

.....

(ii) Another kettle has twice as much power.

It is connected to the same mains supply.

Which of these fuse ratings should be used for this kettle?

(1)

- A 1 A
- B 3 A
- C 5 A
- D 13 A



3 A toy train is placed on the middle of a bridge on a model railway.

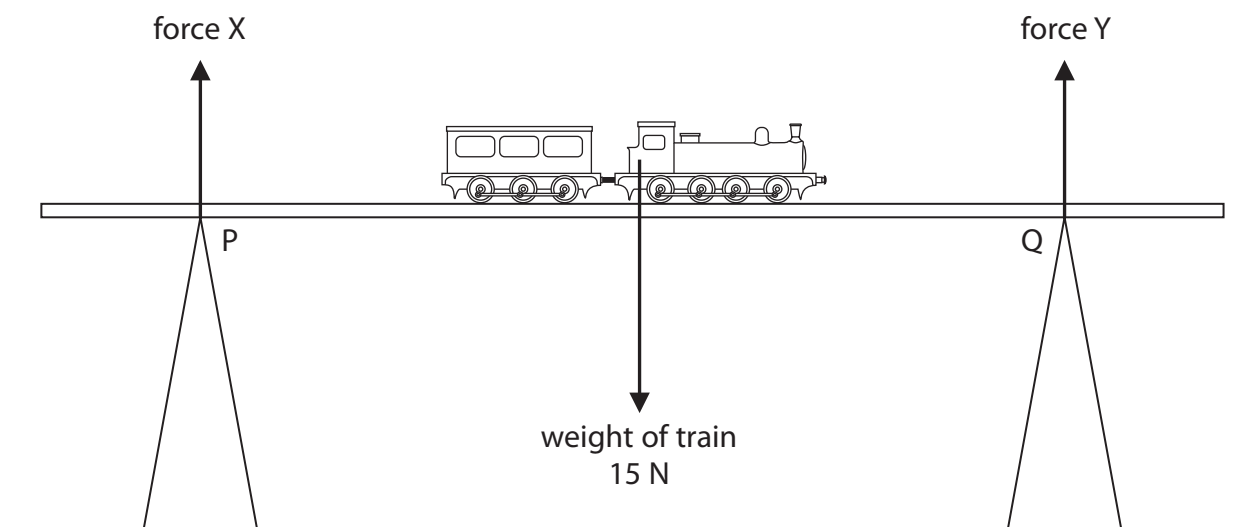

The weight of the train acts through its centre of gravity.

Ignore the weight of the bridge.

(a) Which row of the table shows the correct values for forces X and Y?

(1)

	force X	force Y
<input type="checkbox"/> A	7.5 N	7.5 N
<input type="checkbox"/> B	0 N	0 N
<input type="checkbox"/> C	0 N	15 N
<input type="checkbox"/> D	15 N	0 N

(b) Describe how force X changes if the train moves from P to Q.

(2)

.....

.....

.....

.....

(Total for Question 3 = 3 marks)



4 The photograph shows a water barrel with a tap.

The barrel is used to store rainwater.



A student investigates the water depth in the barrel.

She measures the depth and then opens the tap.

As water flows out of the barrel, she measures the depth every minute.

The table shows her results.

Time in minutes	Depth in cm
0	86
1	52
2	31
3	18
4	11
5	7
6	4

(a) Which two measuring instruments should the student use in her investigation?

(2)

1

2



(b) (i) Plot a graph to show how the depth changes with time, and draw the curve of best fit.

(5)

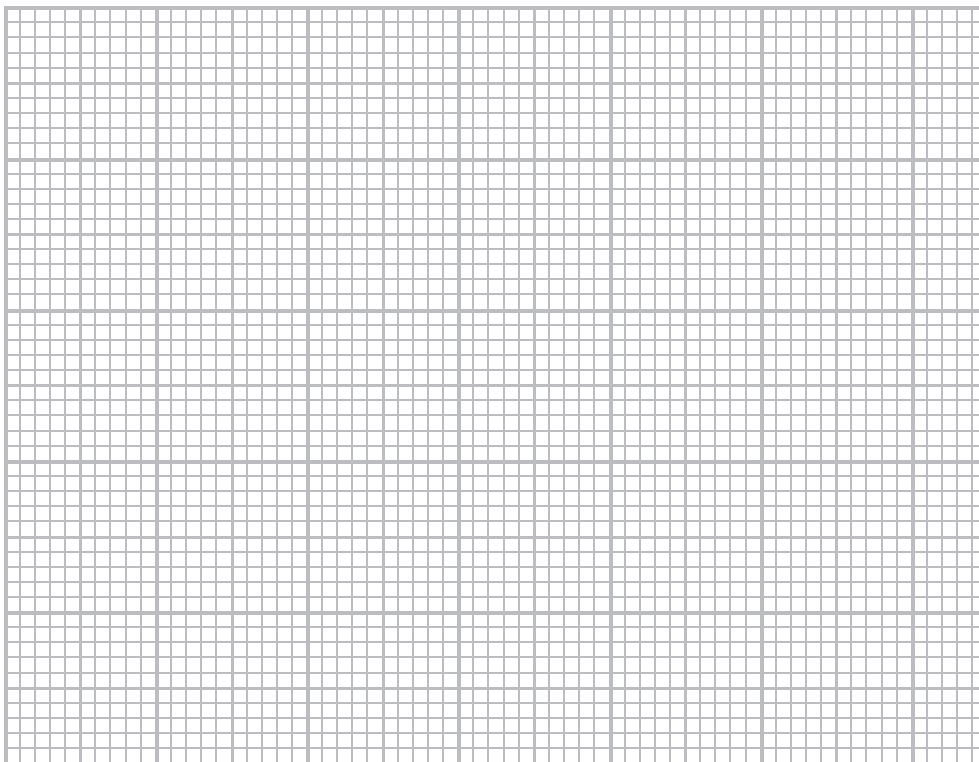

(ii) Describe the relationship between depth and time.

(2)

.....

.....

.....

.....

(c) The student notices that the water flows out less quickly as time passes.

Suggest a reason for the decrease in flow.

(1)

.....

.....

.....

(Total for Question 4 = 10 marks)



5 An ice skater throws a 0.23 kg snowball with a velocity of 13 m/s.

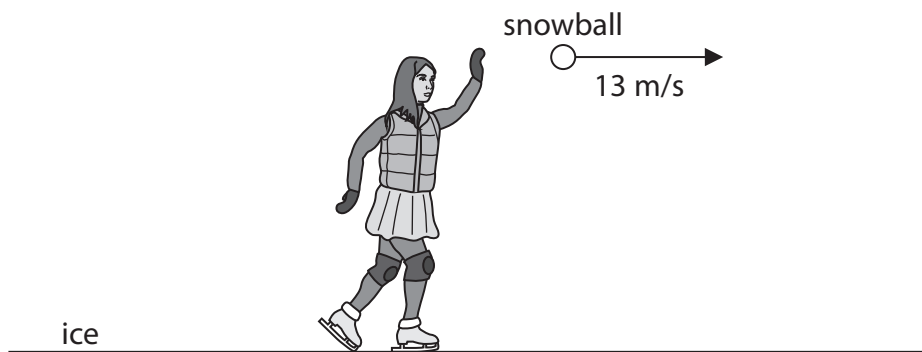

(a) (i) State the equation linking momentum, mass and velocity. (1)

(ii) Calculate the initial momentum of the snowball. (2)

initial momentum = kg m/s

(b) When the skater throws the snowball forwards, she slides backwards on the ice. Explain why she moves in this direction. (3)

.....

.....

.....

.....

.....

.....

.....

.....

.....

.....



(c) The skater wears soft knee pads that compress easily.

Explain how the pads protect her knees when she falls on the ice.

(3)

.....

.....

.....

.....

.....

.....

.....

.....

.....

.....

.....

(Total for Question 5 = 9 marks)



6 A student holds a roll of sticky tape and pulls the end down as shown in the diagram.

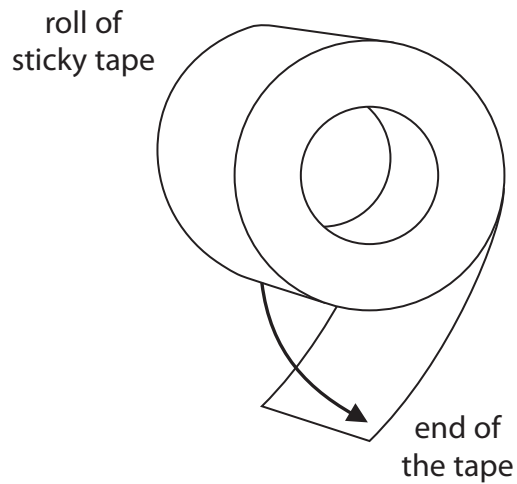

This causes both the roll and the end of the tape to become electrically charged by friction.

(a) Explain how an object becomes charged by friction.

(3)

.....

.....

.....

.....

.....

.....

.....

.....

.....

.....



(b) The student lets go of the end of the tape and the charges cause it to move towards the roll.

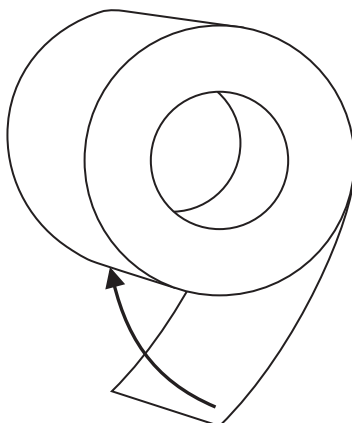

Explain why the end of the tape moves back towards the roll.

(2)

.....

.....

.....

.....

.....

.....

.....

(Total for Question 6 = 5 marks)



(b) The radioactive glass also emits beta particles from a different isotope.

The diagram shows the position of the radioactive glass in the camera.

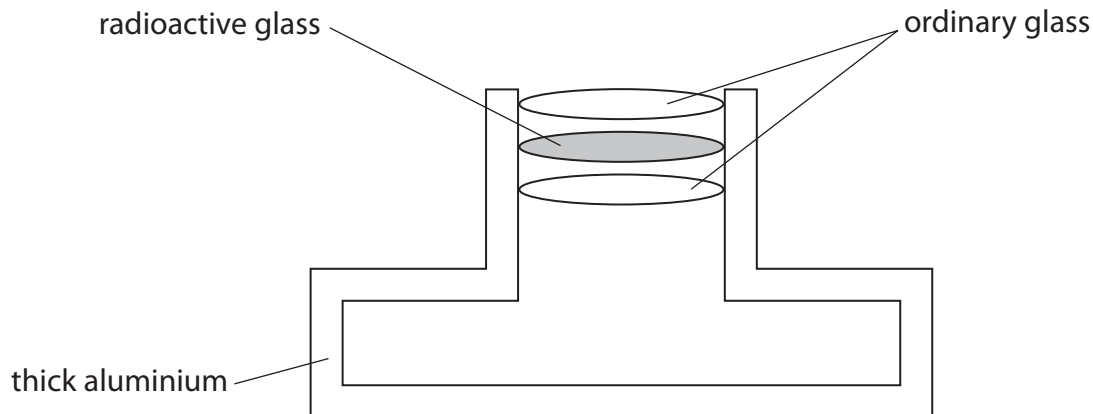

(i) Suggest why it is safe to use radioactive glass in the camera as shown.

(1)

.....

.....

.....

.....

(ii) Amateur astronomers sometimes remove an old camera lens to use as a lens in a homemade telescope.

Suggest why an astronomer should not use a lens with radioactive glass close to their eye.

(2)

.....

.....

.....

.....

.....

.....

.....

(Total for Question 7 = 5 marks)



8 The photographs show how an electric toothbrush fits on its charger.

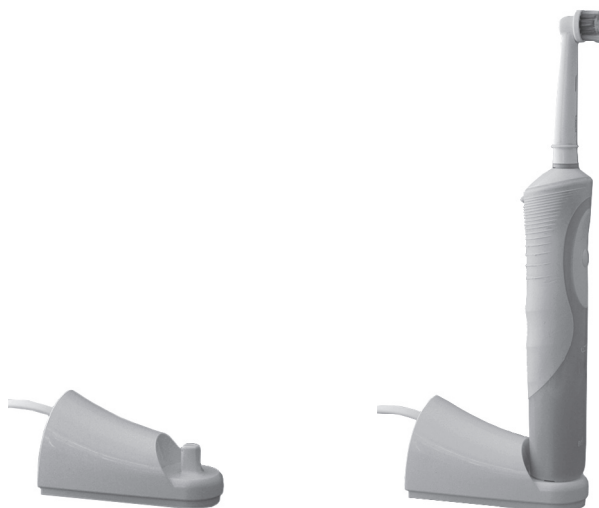

The charger and the toothbrush each have a coil of wire inside them.

The diagram shows how the two coils are linked by a U-shaped core.

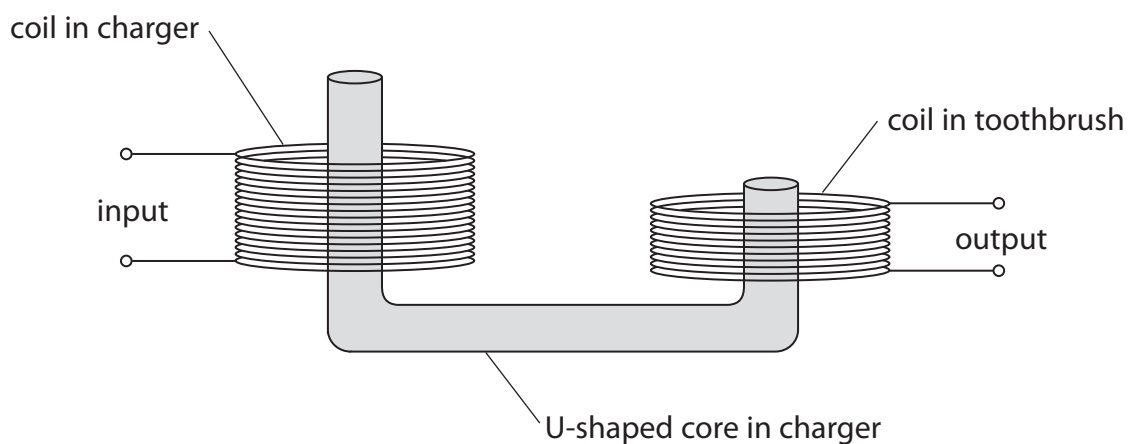

This arrangement of core and coils acts as a transformer that reduces voltage.

(a) (i) Name the type of transformer that reduces voltage. (1)

(ii) Explain why the core is made of a soft magnetic material, such as iron. (2)

(b) (i) State the equation linking the input (primary) and output (secondary) voltages and the turns ratio of a transformer. (1)

(ii) The transformer has 520 primary turns and 30 secondary turns.
The input voltage to the transformer is 44 V.
Calculate the output voltage. (2)

output voltage = V



(c) (i) The alternating current in the transformer has a frequency of 27 000 Hz.
The toothbrush vibrates at the same frequency when it is being charged.
Explain why these vibrations cannot be heard.

(2)

.....

.....

.....

.....

(ii) A circuit in the toothbrush delivers regular pulses of direct current.
There is a pulse every 1.5 ms.
Calculate the frequency of the pulses.

(2)

frequency = Hz

(Total for Question 8 = 10 marks)

TOTAL FOR PAPER = 60 MARKS

Every effort has been made to contact copyright holders to obtain their permission for the use of copyright material. Pearson Education Ltd. will, if notified, be happy to rectify any errors or omissions and include any such rectifications in future editions.

