

Cambridge
International
AS & A Level

Cambridge Assessment International Education
Cambridge International Advanced Subsidiary and Advanced Level

CANDIDATE
NAME

--

CENTRE
NUMBER

--	--	--	--	--

CANDIDATE
NUMBER

--	--	--	--



COMPUTER SCIENCE

9608/33

Paper 3 Advanced Theory

May/June 2019

1 hour 30 minutes

Candidates answer on the Question Paper.

No Additional Materials are required.

No calculators allowed.

READ THESE INSTRUCTIONS FIRST

Write your centre number, candidate number and name in the spaces at the top of this page.

Write in dark blue or black pen.

You may use an HB pencil for any diagrams, graphs or rough working.

Do not use staples, paper clips, glue or correction fluid.

DO NOT WRITE IN ANY BARCODES.

Answer **all** questions.

No marks will be awarded for using brand names of software packages or hardware.

At the end of the examination, fasten all your work securely together.

The number of marks is given in brackets [] at the end of each question or part question.

The maximum number of marks is 75.

This document consists of **13** printed pages and **3** blank pages.

1 In a computer system, real numbers are stored using normalised floating-point representation with:

- twelve bits for the mantissa
- four bits for the exponent.

The mantissa and exponent are both in two's complement form.

(a) Calculate the denary value for the following binary floating-point number.

Show your working.

Mantissa	Exponent																
<table border="1" style="border-collapse: collapse; width: 100%; text-align: center;"> <tr> <td style="width: 20px;">1</td><td style="width: 20px;">0</td><td style="width: 20px;">0</td><td style="width: 20px;">1</td><td style="width: 20px;">0</td><td style="width: 20px;">1</td><td style="width: 20px;">1</td><td style="width: 20px;">1</td><td style="width: 20px;">0</td><td style="width: 20px;">0</td><td style="width: 20px;">1</td><td style="width: 20px;">1</td> </tr> </table>	1	0	0	1	0	1	1	1	0	0	1	1	<table border="1" style="border-collapse: collapse; width: 100%; text-align: center;"> <tr> <td style="width: 20px;">0</td><td style="width: 20px;">1</td><td style="width: 20px;">1</td><td style="width: 20px;">1</td> </tr> </table>	0	1	1	1
1	0	0	1	0	1	1	1	0	0	1	1						
0	1	1	1														

Working

.....

.....

.....

.....

Answer [3]

(b) Calculate the normalised floating-point representation of +1.5625 in this system.

Show your working.

Working

.....

.....

.....

.....

Mantissa	Exponent																
<table border="1" style="border-collapse: collapse; width: 100%; height: 20px;"> <tr> <td style="width: 20px;"></td><td style="width: 20px;"></td><td style="width: 20px;"></td><td style="width: 20px;"></td><td style="width: 20px;"></td><td style="width: 20px;"></td><td style="width: 20px;"></td><td style="width: 20px;"></td><td style="width: 20px;"></td><td style="width: 20px;"></td><td style="width: 20px;"></td><td style="width: 20px;"></td> </tr> </table>													<table border="1" style="border-collapse: collapse; width: 100%; height: 20px;"> <tr> <td style="width: 20px;"></td><td style="width: 20px;"></td><td style="width: 20px;"></td><td style="width: 20px;"></td> </tr> </table>				

[3]

- (c) (i) Write the largest positive number that can be stored as a normalised floating-point number using this format.

Mantissa

--	--	--	--	--	--	--	--	--	--	--	--	--	--	--	--	--	--	--	--

Exponent

--	--	--	--

[2]

- (ii) Write the smallest non-zero positive number that can be stored as a normalised floating-point number using this format.

Mantissa

--	--	--	--	--	--	--	--	--	--	--	--	--	--	--	--	--	--	--	--

Exponent

--	--	--	--

[2]

- (d) The developer of a new programming language decides that all real numbers will now be stored using 20-bit normalised floating-point representation. She must decide how many bits to use for the mantissa and how many bits for the exponent.

Explain the trade-off between using either a large number of bits for the mantissa, or a large number of bits for the exponent.

.....

.....

.....

.....

.....

.....

.....

.....

[3]

2 Cables connect the computers in a university admissions department in a star topology. The server room contains the server and printer for the employees to use. The department has three employees. Each employee has a computer connected to the star network.

(a) (i) Draw a diagram to show this topology.

[3]

(ii) Explain the benefits to the admissions department of using a star topology.

.....

.....

.....

.....

.....

.....

.....

.....

.....

.....

.....

..... [4]

- (b) Each department of the university has its own network. All the department networks connect to the university's main Local Area Network (LAN). The LAN has a bus topology and uses the CSMA/CD protocol.

Describe the CSMA/CD protocol.

.....

.....

.....

.....

.....

.....

.....

..... [3]

- (c) Explain how the following devices are used to support the university LAN.

(i) Router

.....

.....

..... [2]

(ii) Network Interface Card (NIC)

.....

.....

..... [2]

(iii) Wireless Access Point

.....

.....

..... [2]

3 (a) The following logic circuit can be simplified to use only one gate.

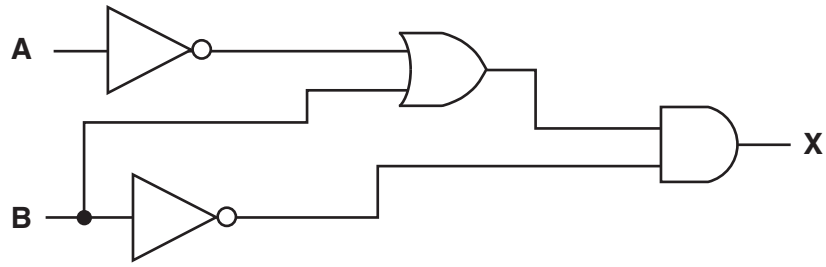

Give the name of this single gate.

..... [1]

(b) (i) Complete the truth table for the logic circuit.

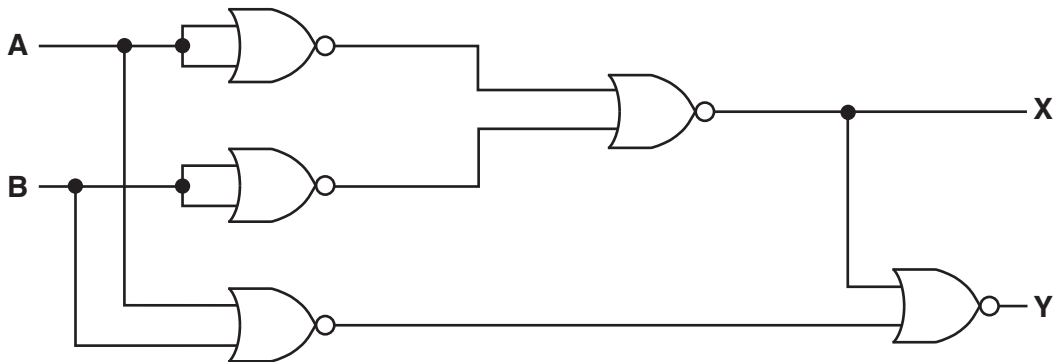

A	B	Working space	X	Y
0	0			
0	1			
1	0			
1	1			

[2]

(ii) Give the name of the logic circuit that has this truth table.

..... [1]

(iii) Give the uses for outputs X and Y.

X

Y

[2]

(c) Consider the following Boolean algebraic expression:

$$\bar{A} \cdot \bar{B} \cdot \bar{C} \cdot \bar{D} + \bar{A} \cdot \bar{B} \cdot \bar{C} \cdot D + \bar{A} \cdot \bar{B} \cdot C \cdot D + \bar{A} \cdot \bar{B} \cdot C \cdot \bar{D} + \bar{A} \cdot B \cdot \bar{C} \cdot \bar{D}$$

Use Boolean algebra to simplify the expression. Show your working.

Working

.....

.....

.....

.....

.....

.....

.....

.....

.....

.....

Simplified expression [5]

4 A compiler uses a keyword table and a symbol table. Part of the keyword table is shown.

- Tokens for keywords are shown in hexadecimal.
- All of the keyword tokens are in the range 00 – 5F.

Keyword	Token
←	01
+	02
=	03
<>	04

IF	4A
THEN	4B
ENDIF	4C
ELSE	4D
REPEAT	4E
UNTIL	4F
TO	50
INPUT	51
OUTPUT	52
ENDFOR	53

Entries in the symbol table are allocated tokens. These values start from 60 (hexadecimal).

Study the following piece of pseudocode.

```

Counter ← 0
INPUT Password
REPEAT
    IF Password <> "Cambridge"
        THEN
            INPUT Password
        ENDIF
    Counter ← Counter + 1
UNTIL Password = "Cambridge"
OUTPUT Counter

```

(a) Complete the symbol table to show its contents after the lexical analysis stage.

Symbol	Token	
	Value	Type
Counter	60	Variable

[3]

(b) The output from the lexical analysis stage is stored in the following table. Each cell stores one byte of the output.

Complete the output from the lexical analysis using the keyword table **and** your answer to **part (a)**.

60	01																			
----	----	--	--	--	--	--	--	--	--	--	--	--	--	--	--	--	--	--	--	--

[2]

(c) The following table shows assembly language instructions for a processor which has one general purpose register, the Accumulator (ACC).

Instruction		Explanation
Op code	Operand	
LDD	<address>	Direct addressing. Load the contents of the location at the given address to ACC
ADD	<address>	Add the contents of the given address to the ACC
STO	<address>	Store the contents of ACC at the given address

After the syntax analysis is completed successfully, the compiler generates object code.

The following lines of high level language code are compiled.

```
X = X + Y
Z = Z + X
```

The compilation produces the assembly language code as follows:

```
LDD 236
ADD 237
STO 236
LDD 238
ADD 236
STO 238
```

(i) The final stage in the compilation process that follows this code generation stage is code optimisation.

Rewrite the equivalent code after optimisation.

.....

.....

.....

.....

.....

.....

..... [3]

(ii) Explain why code optimisation is necessary.

.....

.....

.....

..... [2]

- 5 (a) Wiktor is an employee of a travel agent. He uses asymmetric encryption to send confidential information to his manager.

Fill in the spaces with an appropriate term to complete the descriptions.

Asymmetric encryption uses different for encrypting and decrypting data. When Wiktor sends a message to his manager, the message is encrypted into using his manager's key. When the manager receives the message, it is decrypted using her key.

When the manager replies, the message is encrypted using Wiktor's key, and when Wiktor receives the message, it is decrypted into using his key. [5]

- (b) When customers pay for their travel booking online, a secure connection is established using Secure Socket Layer (SSL).

Explain how the customer's browser and the server used to collect the payment will establish a secure connection.

.....

.....

.....

.....

.....

.....

.....

.....

.....

.....

.....

.....

.....

.....

.....

.....

.....

.....

.....

.....

.....

.....

..... [6]

(c) The manager is concerned about the threat of malware to the company computer systems.

Name **two** types of malware. State what the company should do to help prevent the effect of the malware.

The two methods of prevention must be different.

Malware type 1

Prevention

.....

Malware type 2

Prevention

.....

[4]

6 Monitoring and control systems have many different applications.

(a) Explain the importance of feedback in a control system.

.....
.....
.....
.....
.....
..... [3]

(b) An indoor swimming pool is to be kept at a constant temperature of 28 degrees.

Describe the use of feedback in this control system.

.....
.....
.....
.....
.....
.....
.....
.....
..... [4]

(c) Give **one** example of a monitoring system. Explain why this is a monitoring system.

Monitoring system

.....

Explanation

.....
.....
..... [3]

Permission to reproduce items where third-party owned material protected by copyright is included has been sought and cleared where possible. Every reasonable effort has been made by the publisher (UCLES) to trace copyright holders, but if any items requiring clearance have unwittingly been included, the publisher will be pleased to make amends at the earliest possible opportunity.

To avoid the issue of disclosure of answer-related information to candidates, all copyright acknowledgements are reproduced online in the Cambridge Assessment International Education Copyright Acknowledgements Booklet. This is produced for each series of examinations and is freely available to download at www.cambridgeinternational.org after the live examination series.

Cambridge Assessment International Education is part of the Cambridge Assessment Group. Cambridge Assessment is the brand name of the University of Cambridge Local Examinations Syndicate (UCLES), which itself is a department of the University of Cambridge.