



# Cambridge International AS & A Level

CANDIDATE  
NAME

CENTRE  
NUMBER

--	--	--	--	--

CANDIDATE  
NUMBER

--	--	--	--



**BIOLOGY**

**9700/31**

Paper 3 Advanced Practical Skills 1

**October/November 2023**

**2 hours**

You must answer on the question paper.

You will need: The materials and apparatus listed in the confidential instructions

## INSTRUCTIONS

- Answer **all** questions.
- Use a black or dark blue pen. You may use an HB pencil for any diagrams or graphs.
- Write your name, centre number and candidate number in the boxes at the top of the page.
- Write your answer to each question in the space provided.
- Do **not** use an erasable pen or correction fluid.
- Do **not** write on any bar codes.
- You may use a calculator.
- You should show all your working and use appropriate units.

## INFORMATION

- The total mark for this paper is 40.
- The number of marks for each question or part question is shown in brackets [ ].

For Examiner's Use	
1	
2	
<b>Total</b>	

This document has **12** pages. Any blank pages are indicated.

- 1 You will investigate the effect of temperature on the production of carbon dioxide gas by yeast cells.

Yeast cells contain enzymes that break down glucose to release carbon dioxide and ethanol as shown in Fig. 1.1.

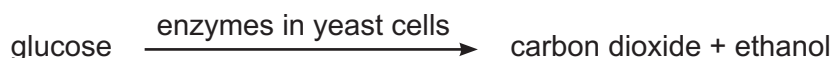

**Fig. 1.1**

You are provided with the materials shown in Table 1.1.

**Table 1.1**

labelled	contents	hazard	volume/cm <sup>3</sup>
<b>Y</b>	yeast cell suspension	none	100
<b>G</b>	glucose solution	none	20
<b>H</b>	hydrogencarbonate indicator	harmful irritant	15

If any solution comes into contact with your skin, wash off immediately under cold water.

It is recommended that you wear suitable eye protection.

You will need to:

- maintain samples of a yeast cell suspension at different temperatures
  - count the number of bubbles of carbon dioxide produced.
- (a) (i) Decide which temperatures you will use for your investigation. These temperatures should be below 65 °C.

State the temperatures that you will use in your investigation.

.....  
[2]

Carry out step 1 to step 9.

- step 1 Use the beakers labelled **water-bath**, **hot water** and **cold water** to set up and maintain a water-bath at the highest temperature you stated in (a)(i). The temperature of the water-bath must be maintained.
- step 2 Stir the yeast cell suspension, **Y**, and put 20 cm<sup>3</sup> of **Y** into the large test-tube.
- step 3 Add 1 cm<sup>3</sup> of glucose solution, **G**, to the large test-tube and mix well.
- step 4 Set up the apparatus as shown in Fig. 1.2.

You will use the same test-tube of hydrogencarbonate indicator for each trial.

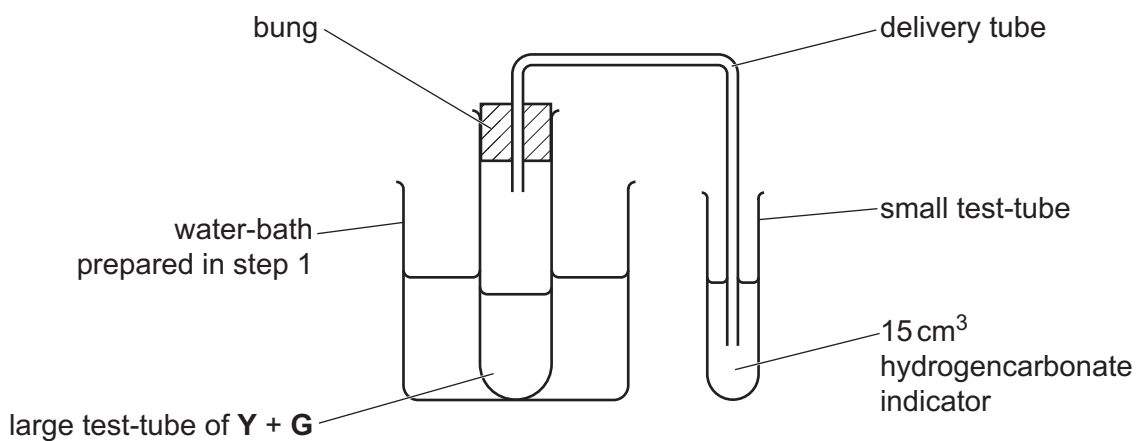

**Fig. 1.2**

step 5 Start timing and leave the apparatus for 60 seconds.

step 6 After 60 seconds, start counting the number of bubbles produced during the next 60 seconds.

Record your result in **(a)(ii)**.

step 7 Take the large test-tube out of the water-bath and remove the bung and delivery tube. Pour the contents of the large test-tube into the container labelled **For Waste**.

step 8 Adjust the temperature of the water-bath to the next highest temperature you stated in **(a)(i)**.

step 9 Repeat step 2 to step 8 until you have tested all the temperatures stated in **(a)(i)**.

**(ii)** Record your results in an appropriate table.

- (iii) State the dependent variable in this investigation.  
 ..... [1]
- (iv) Observe the final colour of the hydrogencarbonate indicator.  
 State the final colour of the hydrogencarbonate indicator ..... [1]
- (v) Suggest **one** conclusion from your observation in (a)(iv).  
 .....  
 ..... [1]
- (vi) Identify **one** source of error in the procedure. Suggest an improvement to reduce this source of error.  
 error .....  
 .....  
 improvement .....  
 ..... [2]

- (b) A student investigated the effect of copper ions on the growth of yeast cells.

Six yeast suspensions were made. For each suspension, 0.4 g of yeast was added to a nutrient solution. Different concentrations of copper ions were added to each yeast suspension. The mass of yeast in each suspension was measured after 24 hours.

The results are shown in Table 1.2.

**Table 1.2**

<b>concentration of copper ions /parts per million (ppm)</b>	<b>mass of yeast /g</b>
0.00	19.4
0.10	21.2
0.25	5.6
0.50	2.0
0.75	0.8
1.00	0.4

(i) Plot a graph of the data shown in Table 1.2 on the grid in Fig. 1.3.

Use a sharp pencil.

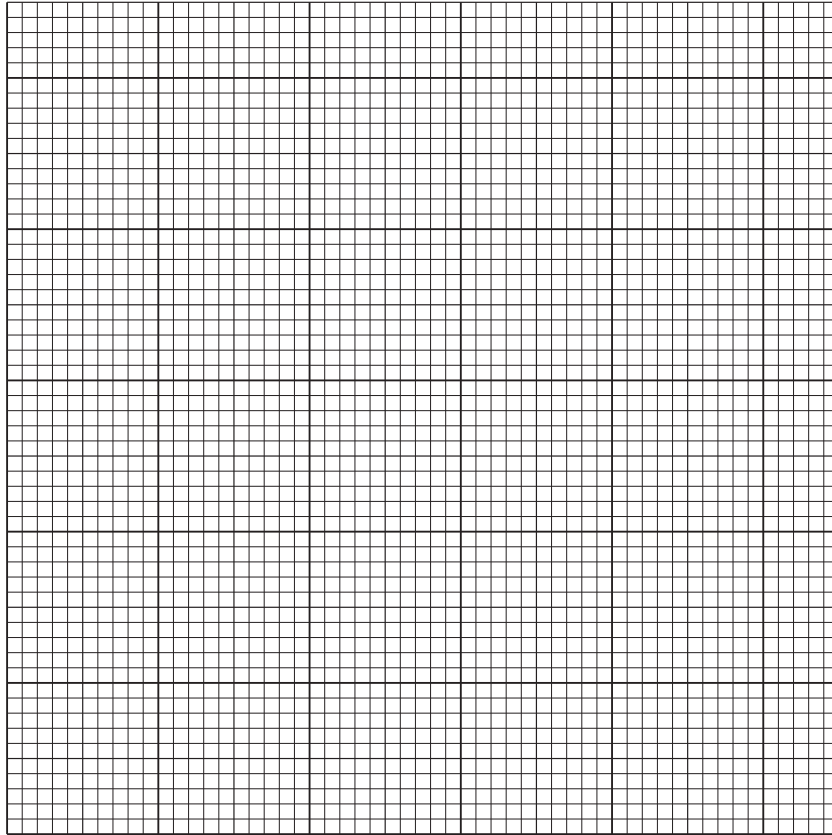

Fig. 1.3

[4]

(ii) Use your graph in Fig. 1.3 to estimate the concentration of copper ions that would result in a mass of 10.0g of yeast cells.

Show on your graph how you obtained your answer.

concentration of copper ions = ..... ppm  
[2]

(iii) Copper ions act as non-competitive inhibitors for some enzymes.

Suggest an explanation for the results shown in your graph in Fig. 1.3.

.....  
.....  
.....  
.....  
..... [2]

- (iv) Until the 1930s, most commercial fermenting equipment for growing yeast cells was made of copper. After this time, fermenting equipment was made using stainless steel instead of copper.

Use your graph in Fig. 1.3 to suggest why stainless steel was used instead of copper.

.....  
.....  
..... [1]

[Total: 21]

2 **J1** is a slide of a stained transverse section through a plant stem.

- (a) (i) Draw a large plan diagram of the region of the stem on **J1** indicated by the shaded area in Fig. 2.1. Use a sharp pencil.

Use **one** ruled label line and label to identify **one** vascular bundle.

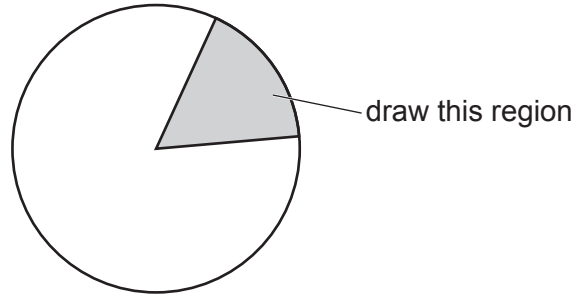

**Fig. 2.1**

[5]

(ii) Observe one vascular bundle of the section on **J1**.

Select **one** large xylem vessel element and a group of **three** adjacent, smaller xylem vessel elements.

- Make a large drawing of this group of **four** xylem vessel elements.
- Use **one** ruled label line and label to identify the cell wall.



(b) Fig. 2.2 is a photomicrograph showing the epidermis from another type of plant.

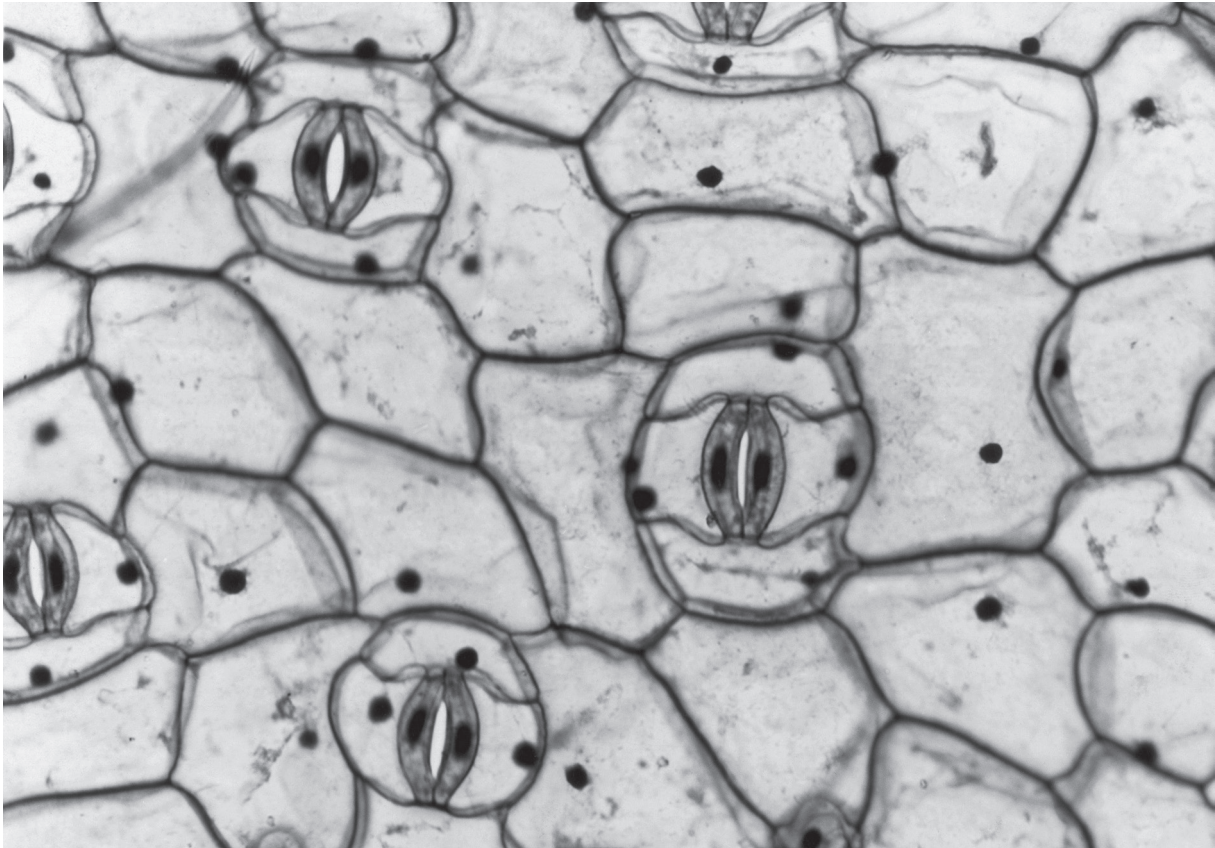

**Fig. 2.2**

The actual area of the epidermis visible in the photomicrograph in Fig. 2.2 is  $0.04 \text{ mm}^2$ .

The leaf from which Fig. 2.2 is taken has a total surface area of  $2000 \text{ mm}^2$ .

(i) Use Fig. 2.2 to estimate the total number of stomata on the leaf.

Show your working.

total number of stomata = .....

[3]

- (ii) One way to improve the accuracy of the estimate of the total number of stomata on a leaf is to use a photomicrograph with a larger area.

State **one** other way to improve the accuracy of the estimate of the total number of stomata on a leaf.

.....  
.....  
..... [1]

- (iii) Fig. 2.3 and Fig. 2.4 are photomicrographs of sections through the leaf surface of two different plants.

The photomicrographs in Fig. 2.3 and Fig. 2.4 have the same magnification.

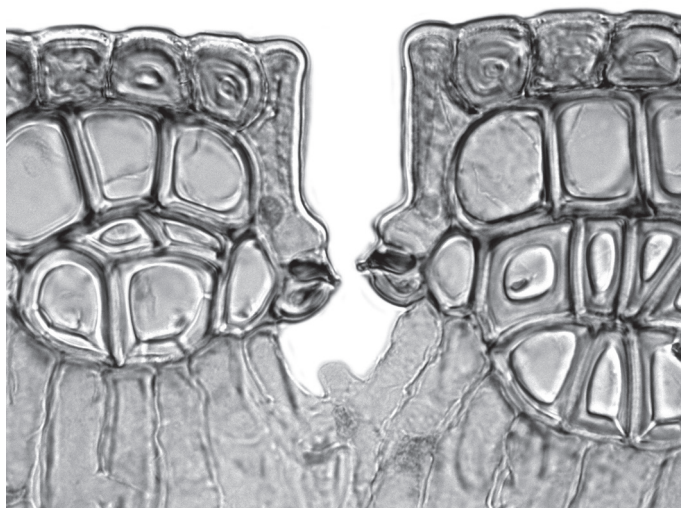

Fig. 2.3

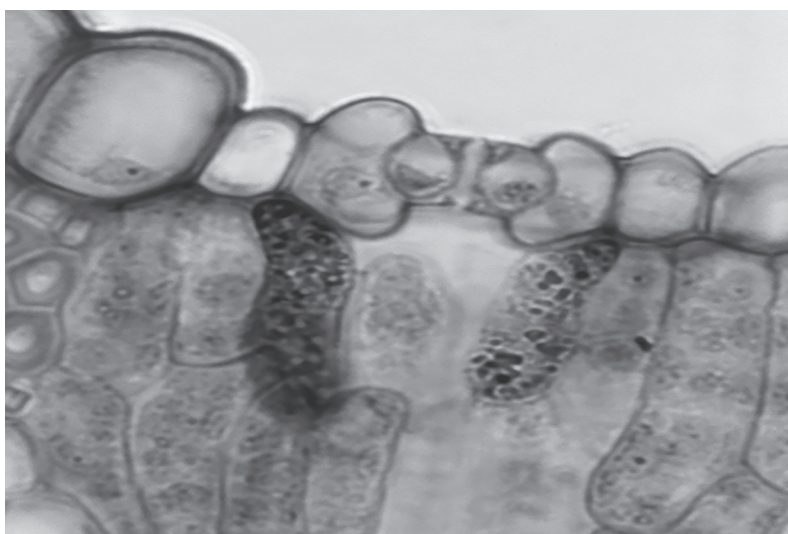

Fig. 2.4

Identify **three** observable differences between the leaf section shown in Fig. 2.3 and the leaf section shown in Fig. 2.4.

Record these **three** observable differences in Table 2.1.

**Table 2.1**

feature	Fig. 2.3	Fig. 2.4

[4]

(iv) Suggest the environment where the plant shown in Fig. 2.3 has grown.

.....  
 ..... [1]

[Total: 19]

**BLANK PAGE**

---

Permission to reproduce items where third-party owned material protected by copyright is included has been sought and cleared where possible. Every reasonable effort has been made by the publisher (UCLES) to trace copyright holders, but if any items requiring clearance have unwittingly been included, the publisher will be pleased to make amends at the earliest possible opportunity.

To avoid the issue of disclosure of answer-related information to candidates, all copyright acknowledgements are reproduced online in the Cambridge Assessment International Education Copyright Acknowledgements Booklet. This is produced for each series of examinations and is freely available to download at [www.cambridgeinternational.org](http://www.cambridgeinternational.org) after the live examination series.

Cambridge Assessment International Education is part of Cambridge Assessment. Cambridge Assessment is the brand name of the University of Cambridge Local Examinations Syndicate (UCLES), which is a department of the University of Cambridge.